

# VERSA-LOK<sup>®</sup>

## Mosaic Wall System

A VERSA-LOK RETAINING WALL SYSTEM

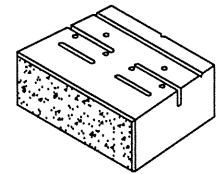
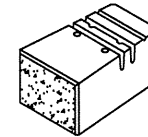
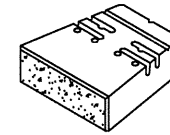
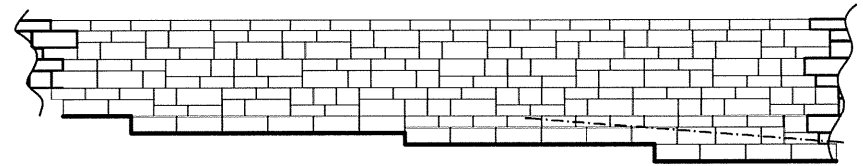

## ST. LOUIS COUNTY MASTERPLAN

### Index of Drawings:

Sheet 1	Title and Index
Sheet 2	Applications and Design Information
Sheet 3	Specifications
Sheet 4,5,6,7	Typical Details
Sheet 8	Standard Design - Horizontal Backfill
Sheet 9	Standard Design - Sloping Backfill
Sheet 10	Standard Design - Tiered Wall

Aspen Consultants  
Edward T. Austin, P.E.  
293 Northwest Blvd  
Fenton, MO 63026  
636/349-2225

**VERSA-LOK**  
Mosaic Wall System

Kirchner Block and Brick  
12901 St. Charles Rock Rd  
Bridgeton, MO 63044  
314/291-3200  
314/291-0265 fax

**COVER SHEET**

Sheet 1 of 10

Date: May 2008

## APPLICATION

The Versa-lok Mosaic retaining wall system is a reinforced soil structure combining an architecturally attractive concrete facing block with geogrid reinforcement. The geogrid reinforcement interlocks with the Versa-lok Mosaic block units and fill soil to create a stable gravity retaining wall. Design of these reinforced soil structures uses well established guidelines that are readily available. The following specifications and details provide a design to incorporate geogrid reinforcement into the soil for the purposes of constructing retaining walls. Consult Kirchner Block and Brick for additional details regarding design, appearance, and aesthetic considerations.

## STANDARD DESIGN PROCEDURE

The following design tables established for the construction of soil reinforced walls are based upon generally accepted soil parameters in the St. Louis County, Missouri area. An engineer shall review the site conditions and the soil present at the proposed location of the soil reinforced walls to determine if the actual conditions match the assumed parameters. All soil parameters assumed in the design are well drained, long term strength conditions. High plastic silts, and clays should be avoided without specific design recommendations from local geotechnical engineers. Frost heave and settlement need to be addressed if warranted by conditions. Also, special precautions are necessary for walls constantly in contact with water, i.e. near or at rivers, lakes, and ponds.

Three typical geometric cases were selected for these tables. The first case is a typical retaining wall with horizontal backfill, the second case is a 3:1 sloping backfill, and the third case is a tiered wall. The horizontal backfill layout is designed with 100 lb per sf surcharge. The following is a summary of the design parameters used and the minimum factors of safety which the tables are based on.

### SOIL PROPERTIES:

	Friction Angle (degrees)	Unit Weight (#/cf)	Cohesion (#/sf)
Wall fill	28	120	0
Retained Backfill	28	120	0
Foundation Soil	28	120	0

Friction Angle - degrees  
Unit Weight - lbs per cf  
Cohesion - lbs per sf

### MINIMUM FACTORS OF SAFETY CALCULATED

Reinforcement Pullout = 1.5  
Reinforcement Rupture = 1.5  
External Sliding = 1.5  
Overturning = 2.0  
Overall for Unknowns = 1.5  
Bearing Capacity = 2000 psf

**VERSA-LOK**  
Mosaic Wall System

Kirchner Block and Brick  
12901 St. Charles Rock Rd  
Bridgeton, MO 63044  
314/291-3200  
314/291-0265 fax

**APPLICATION**

Sheet 2 of 10

Date: May 2008

**SPECIFICATIONS - St. Louis County Masterplan**

**Materials**

**Retaining wall units** shall be Versa-lok Mosaic block units as manufactured by Kirchner Block and Brick. The Mosaic wall system consists of 3 wall units of various sizes each being 12" deep. Concrete wall units shall meet the requirements of ASTM C1372-01 with the maximum water absorption shall be limited to 8.0 percent.

**The reinforced wall backfill** material shall be compacted soil from on-site. The soil shall be free of clumps, free of rocks larger than 4", and free of organic materials. Do not use high plastic soils that have a PI>20 or LL>40.

**Geogrids** shall be Miragrid 2XT, or 3XT as manufactured by Ten Cate Mirafi or SG150 or SG200 as manufactured by Strata Systems Inc. All of these geogrid designations meet the strength requirements of the design calculations. The **geotextile filter fabric** shall be a nonwoven fabric with a minimum weight of 3.5oz/sy.

**The leveling pad** shall be constructed of well graded crushed limestone similar to 1" minus.

**The drainage rock** shall be free draining rock such as 3/4" clean crushed limestone.

**The perforated pipe** shall be HDPE coil pipe.

**Wall Foundation**

Foundation soil shall be excavated as required for the leveling pad and the reinforced fill zone to the depths and locations shown on the plan sheet. The exposed foundation soil shall be observed prior to construction to verify that the exposed material is suitable for a net design bearing pressure of 2000 psf and that the base of the excavation is free of loose soil, uncompacted fill, water, or frozen material. Undercut any unsuitable soil. Undercut areas shall be filled with crushed limestone and compacted to at least 95% of the material's standard Proctor maximum dry density.

Construct the crushed rock leveling pad to lines and grades shown on the plans.

Construct the horizontal drainage layer at the lines and grades shown on the plans. The 6" of drainage rock shall be separated from the rock with a filter fabric. Place the perforated pipe behind the base unit and in the drainage layer. Slope the pipe to the low point in the wall and daylight the pipe through the wall face.

**Wall Construction**

The Mosaic wall system consists of 3 wall units stacked in various panel patterns to form the retaining wall. The panel layout examples are shown on sheet 4 of 10. Each panel is 10" tall.

Install the first course of units on the leveling pad. The base units are 6" standard Versa-lok units that are stepped in 6" and 4" increments or stepped in 10" increments to match the full panel layout. Install the next panel level with a 3" offset bond pattern. Backfill units and continue construction. Cap units shall be glued in place at the top of the wall.

**Geogrid Reinforcing**

The geogrids shall be cut to design lengths and placed between the blocks at the elevations shown on the plans. The geogrid's primary strength direction will be directed perpendicular to the wall face (into the fill.) The geogrids placed outside a plus or minus 4" zone of the geogrid design elevation will not be accepted. The geogrid shall be placed horizontally and lay flat on the reinforced fill soil. The geogrid shall be placed so that a minimum of 8" of grid is between the block layers. Slack in the geogrid shall be removed prior to placing additional backfill.

**Wall Backfill**

Wall backfill material shall be placed in maximum 8" loose lifts and compacted to at least 95% of the material's maximum dry density as determined by the standard Proctor method. Backfill shall be placed, spread, and compacted in such a manner that minimizes wrinkles and movement of the geogrid. Field density testing shall be conducted by a qualified soils technician to verify that at least the minimum degree of compaction is being obtained.

Place 12" of drainage rock behind units.

During backfill placement the 3 foot zone directly behind the wall shall be limited to the use of hand operated compaction equipment only.

Construction equipment shall not be operated directly on the geogrid.

**Protection of Work**

The surface of the wall backfill shall be graded at the end of each day of work to provide positive surface drainage away from the wall. Grading shall include proper contouring of fills in adjacent areas to prevent the flow of surface water into the reinforced earth zone.

The design of the walls are based on conditions and loads imposed on the wall at completion of the project. Prior to project completion, the wall is vulnerable to damages caused by construction activity adjacent to the wall. Of particular concern is the of grading and pavement construction equipment on the retained backfill at the top of the wall. Only equipment with a weight not exceeding one ton can be used in the 3 foot zone directly behind the back of the wall face.

The soil in front of the walls shall be protected from future erosion.

**VERSA-LOK**  
**Mosaic Wall System**

Kirchner Block and Brick  
12901 St. Charles Rock Rd  
Bridgeton, MO 63044  
314/291-3200  
314/291-0265 fax

**SPECIFICATIONS**

Sheet 3 of 10

Date: May 2008

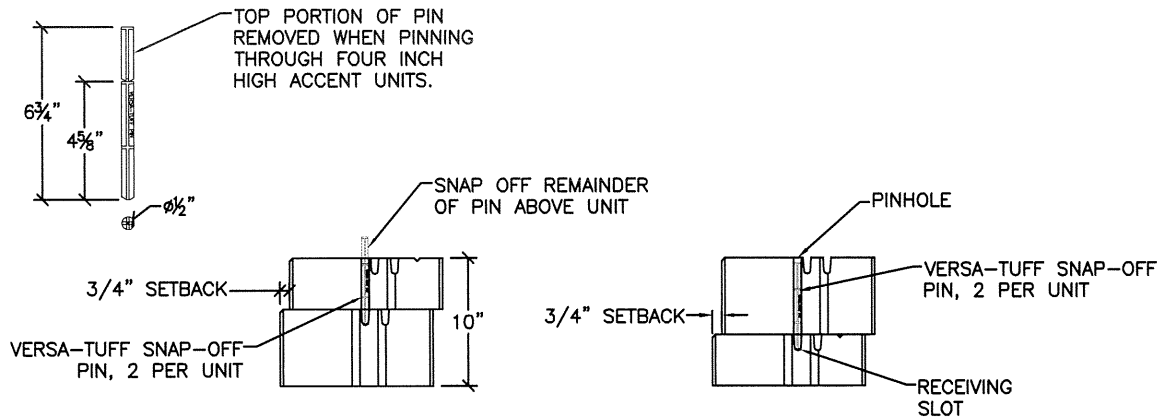

**PINNING DETAILS**

NOT TO SCALE

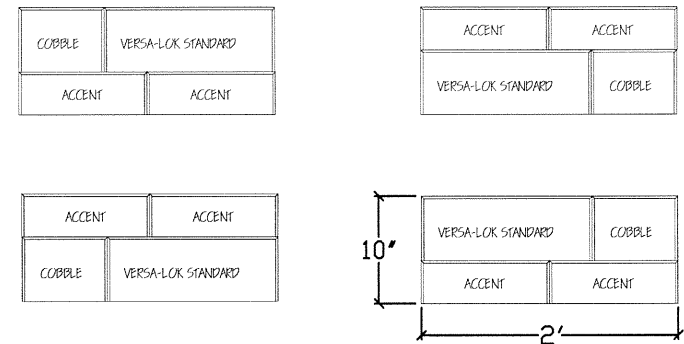

**PANEL ARRANGEMENTS**

NOT TO SCALE

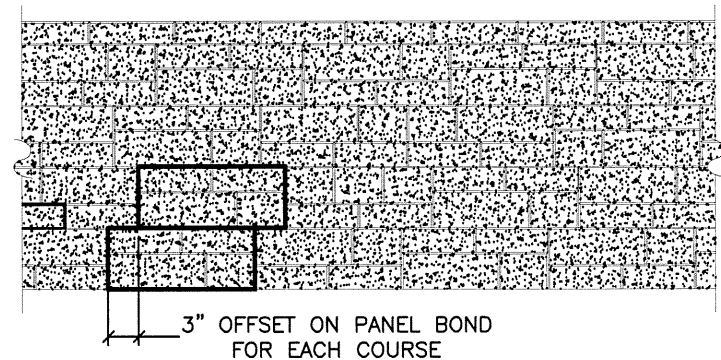
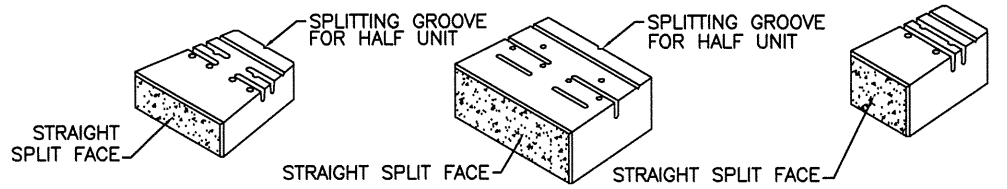

**MOSAIC PATTERN ARRANGEMENTS**

NOT TO SCALE

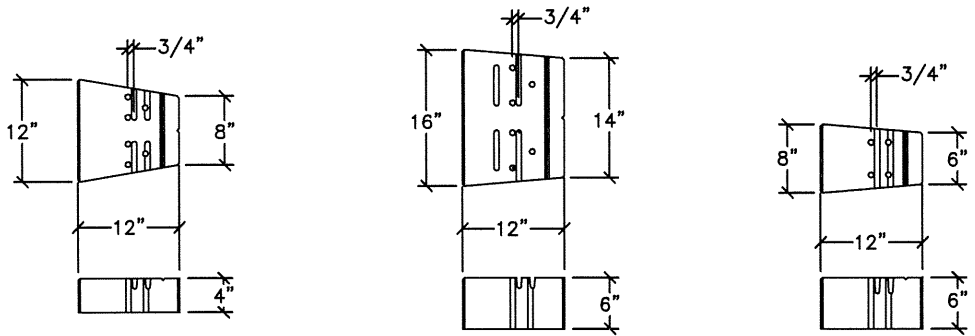

**ACCENT UNIT**

**STANDARD UNIT**

**COBBLE UNIT**

**VERSA-LOK**  
Mosaic Wall System

Kirchner Block and Brick  
12901 St. Charles Rock Rd  
Bridgeton, MO 63044  
314/291-3200  
314/291-0265 fax

**BLOCK DETAILS**

Sheet 4 of 10

Date: May 2008

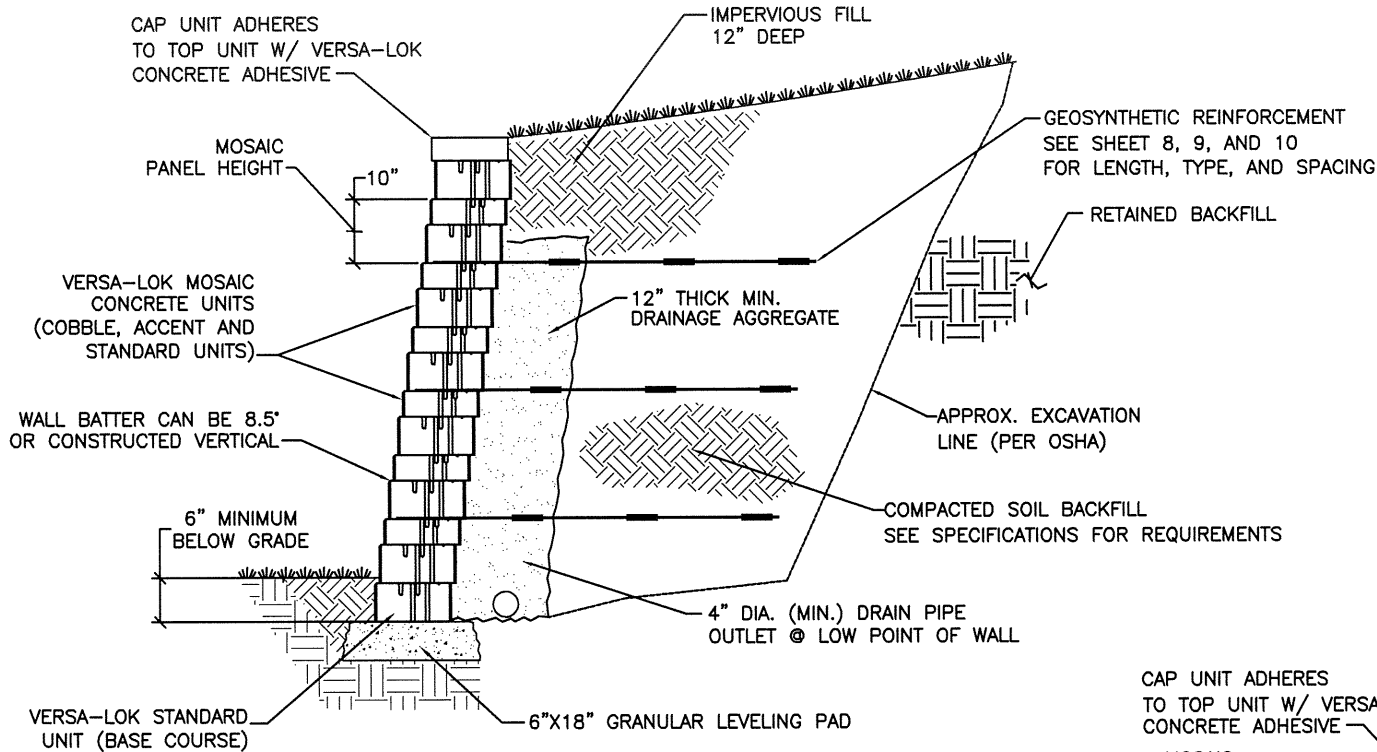

**TYPICAL SECTION – WITH REINFORCEMENT**

NOT TO SCALE

**NOTES:**

1. SURCHARGE LOADS OTHER THAN PARKING LOT LOADS MUST BE LOCATED A MINIMUM 8' BEHIND THE WALL FACE.
2. IF VERTICAL WALL CONSTRUCTION IS CHOSEN THEN PARTICULAR CARE MUST BE GIVEN TO BACKFILL COMPACTION METHODS TO PREVENT OUTWARD MOVEMENT OF THE WALL FACE.

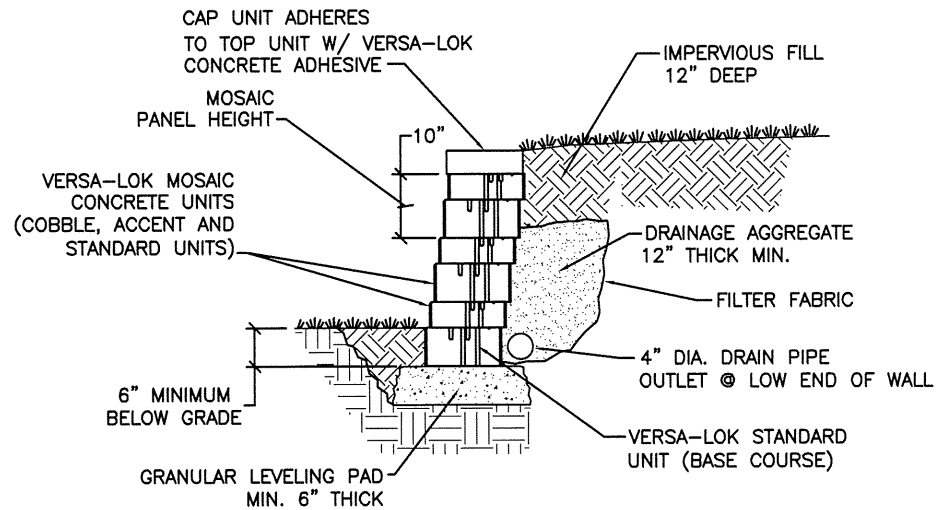

**TYPICAL SECTION – WITHOUT REINFORCEMENT**

NOT TO SCALE

**VERSA-LOK**  
Mosaic Wall System

Kirchner Block and Brick  
12901 St. Charles Rock Rd  
Bridgeton, MO 63044  
314/291-3200  
314/291-0265 fax

**TYPICAL SECTIONS**

Sheet 5 of 10

Date: May 2008

**NOTE:**

1. FOR INSIDE 90° CORNERS THE LOWER UNIT NEAREST THE CORNER OF THE ABUTTING PANEL MUST HAVE 3/4" CUT OFF THE FACE TO ACCOMMODATE THE 3/4" SETBACK OF THE UPPER UNITS IN THE ADJACENT PANEL
2. INSIDE CORNERS OF VARYING ANGLES ARE ALSO POSSIBLE BY FURTHER MODIFYING THE UNITS AT THE CORNER

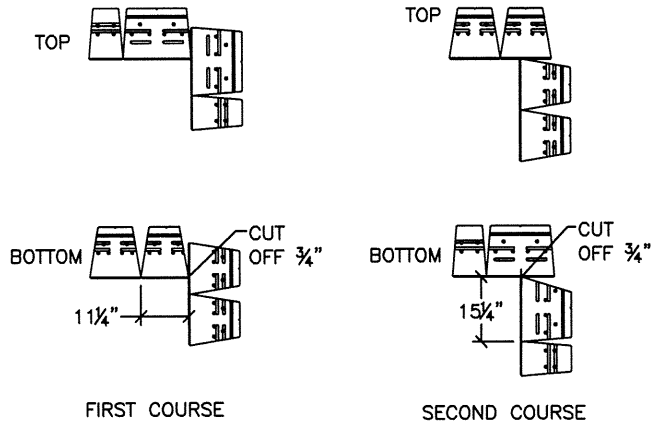

**INSIDE CORNER DETAIL**

NOT TO SCALE

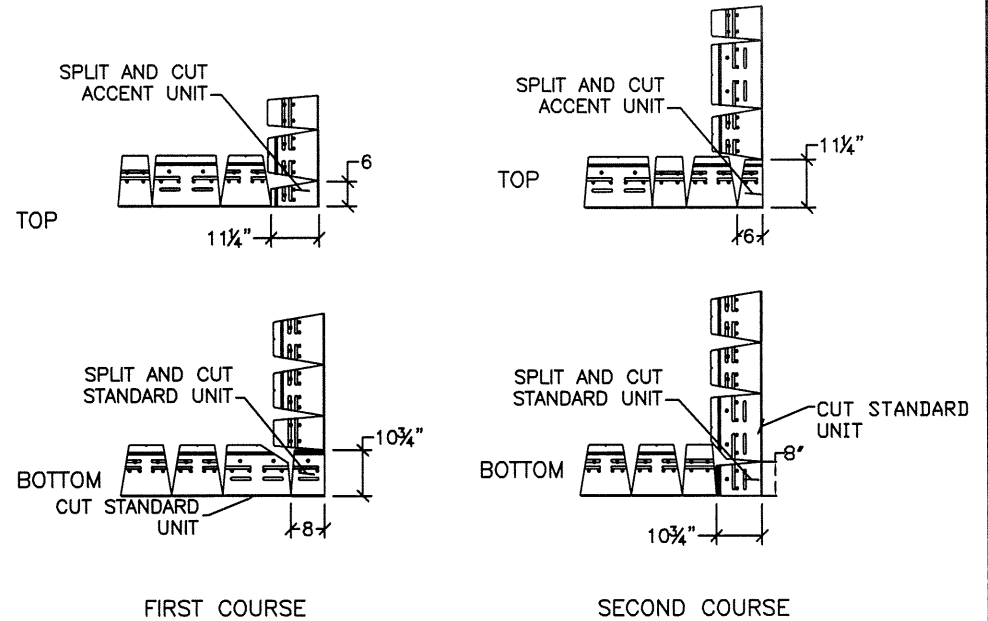

**OUTSIDE CORNER DETAIL**

NOT TO SCALE

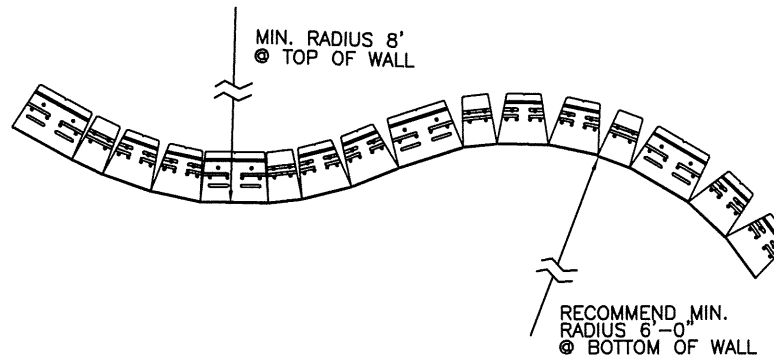

**CURVE DETAIL**

NOT TO SCALE

**VERSA-LOK**  
Mosaic Wall System

Kirchner Block and Brick  
12901 St. Charles Rock Rd  
Bridgeton, MO 63044  
314/291-3200  
314/291-0265 fax

**DETAILS**

Sheet 6 of 10

Date: May 2008

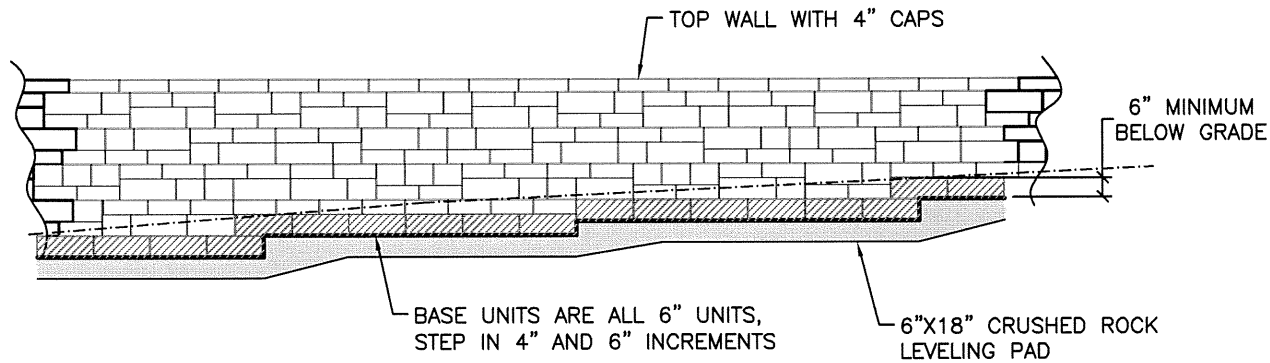
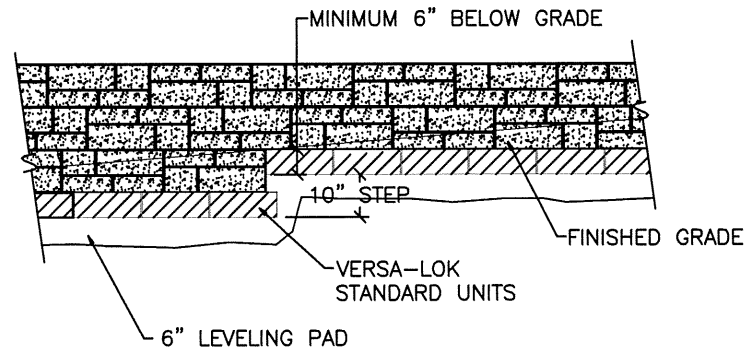
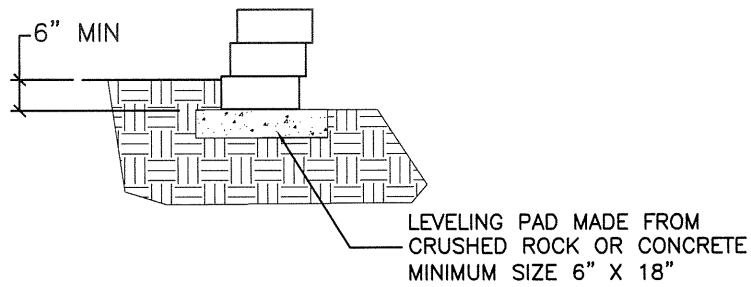

### LEVELING PAD DETAIL

NOT TO SCALE

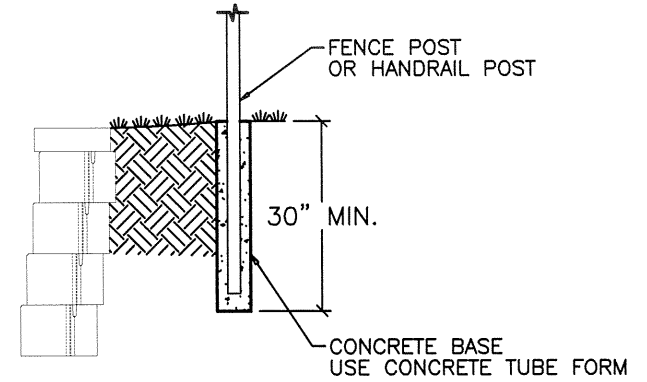

### FENCE DETAIL

NOT TO SCALE

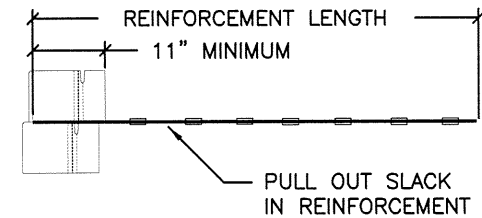

### CONNECTION DETAIL

NOT TO SCALE

TWO LEVELING PAD STEPPING OPTIONS  
DETAILED AND EITHER MAY BE USED

1. 10" STEPS CONSTRUCTED BY STEPPING FULL PANELS
2. 6" AND 4" STEPS CONSTRUCTED BY STEPPING UNITS AS NEEDED

**VERSA-LOK**  
Mosaic Wall System

Kirchner Block and Brick  
12901 St. Charles Rock Rd  
Bridgeton, MO 63044  
314/291-3200  
314/291-0265 fax

**DETAILS**

Sheet 7 of 10

Date: May 2008

NOTES:

1. GEOGRID LENGTH MEASURED FROM FACE OF WALL.
2. GEOGRIDS ARE MIRAGRID 2XT OR 3XT OR STRATAGRID SG150 OR SG200.
3. WALL HEIGHT MEASURED FROM TOP OF LEVELING PAD.
4. SEE TYPICAL SECTION DETAIL FOR BACKFILL REQUIREMENTS AND CONSTRUCTION NOTES.

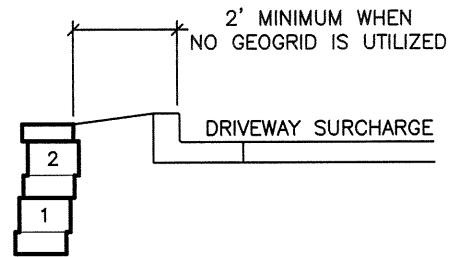

2' TALL WALL

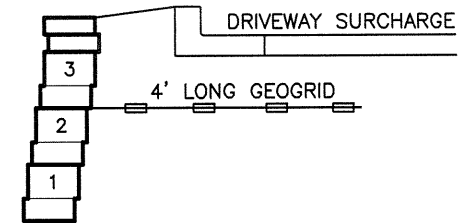

3' TALL WALL

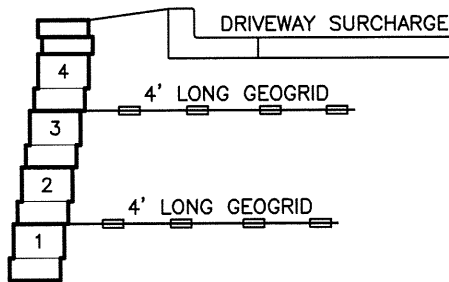

4' TALL WALL

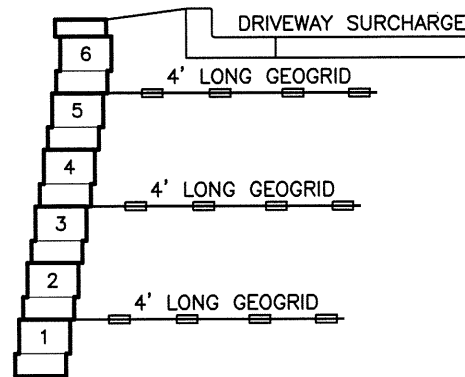

5' TALL WALL

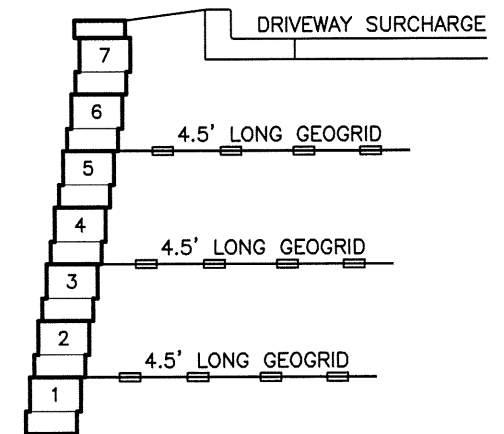

6' TALL WALL

**TYPICAL SECTION – DRIVEWAY SURCHARGE**

NOT TO SCALE

VERTICAL WALL CONSTRUCTION OPTIONS:

- 3' TALL WALL – NO CHANGE
- 4' TALL WALL – NO CHANGE
- 5' TALL WALL – ADD .5' TO GEOGRID LENGTHS
- 6' TALL WALL – ADD .5' TO GEOGRID LENGTHS

**VERSA-LOK**  
Mosaic Wall System

Kirchner Block and Brick  
12901 St. Charles Rock Rd  
Bridgeton, MO 63044  
314/291-3200  
314/291-0265 fax

**HORIZONTAL GRADE**

Sheet 8 of 10

Date: May 2008



NOTES:

1. GEOGRID LENGTH MEASURED FROM FACE OF WALL.
2. GEOGRIDS ARE MIRAGRID 2XT OR 3XT OR STRATAGRID SG150 OR SG200.
3. WALL HEIGHT MEASURED FROM TOP OF LEVELING PAD.
4. SEE TYPICAL SECTION DETAIL FOR BACKFILL REQUIREMENTS AND CONSTRUCTION NOTES.

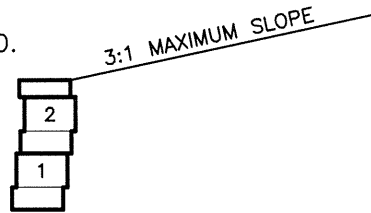

2' TALL WALL

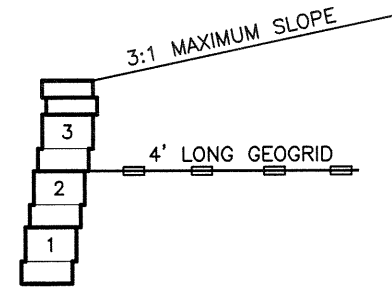

3' TALL WALL

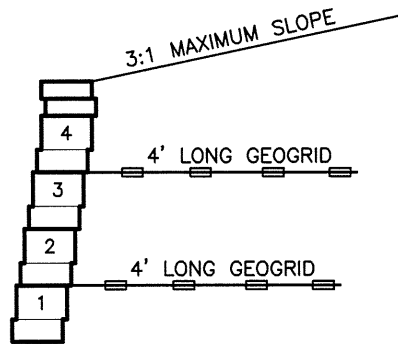

4' TALL WALL

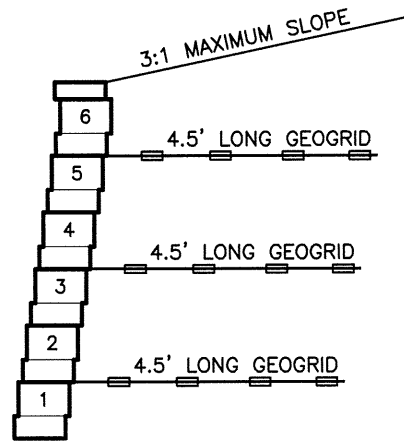

5' TALL WALL

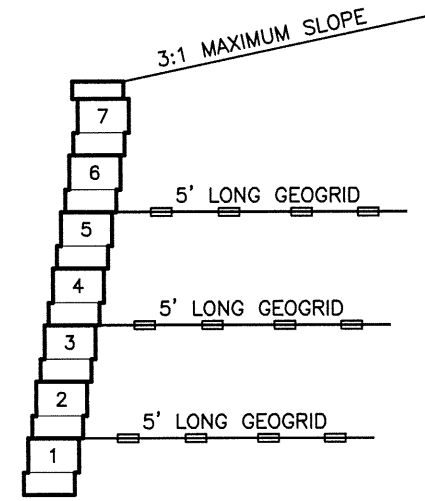

6' TALL WALL

**TYPICAL SECTION – SLOPING FILL**

NOT TO SCALE

VERTICAL WALL CONSTRUCTION OPTIONS:

- 3' TALL WALL – NO CHANGE
- 4' TALL WALL – ADD .5' TO GEOGRID LENGTHS
- 5' TALL WALL – ADD .1' TO GEOGRID LENGTHS
- 6' TALL WALL – ADD .2' TO GEOGRID LENGTHS

**VERSA-LOK**  
Mosaic Wall System

Kirchner Block and Brick  
12901 St. Charles Rock Rd  
Bridgeton, MO 63044  
314/291-3200  
314/291-0265 fax

**SLOPING GRADE**

Sheet 9 of 10

Date: May 2008

NOTES:

1. GEOGRID LENGTH MEASURED FROM FACE OF WALL.
2. GEOGRIDS ARE MIRAGRID 2XT OR MIRAGRID 3XT OR STRATAGRID SG150 OR SG200.
3. WALL HEIGHT MEASURED FROM TOP OF LEVELING PAD.
4. SEE TYPICAL SECTION DETAIL FOR BACKFILL REQUIREMENTS AND CONSTRUCTION NOTES.

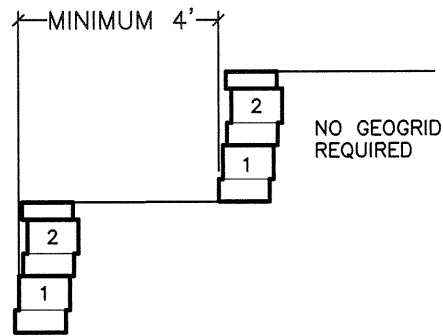

**2' TIERED WALLS**

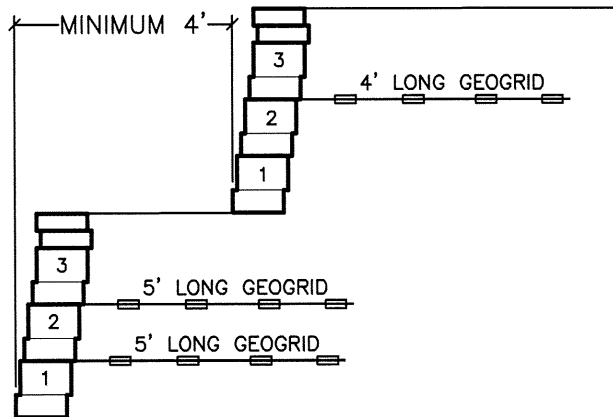

**3' TIERED WALLS**

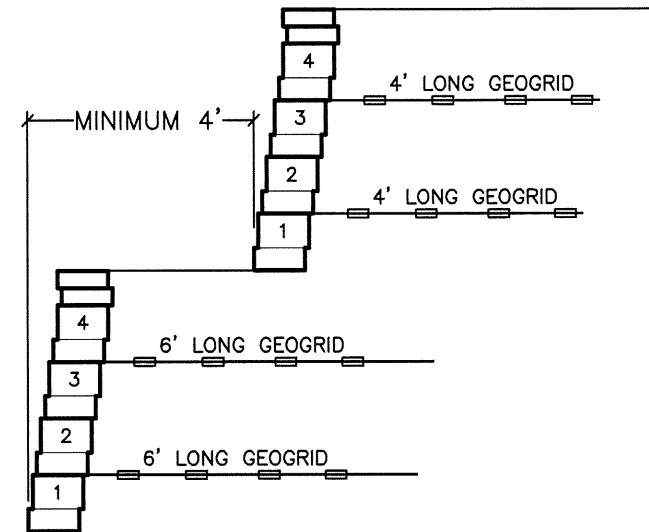

**4' TIERED WALLS**

**TYPICAL SECTION – TIERED WALLS**

NOT TO SCALE

COMPACTED ROCK BACKFILL  
REQUIRED ON BOTTOM WALL TO  
ENDS OF GEOGRIDS TO REDUCE  
SETTLEMENTS OF UPPER WALL

VERTICAL WALL CONSTRUCTION OPTIONS:

- 2' TALL WALL – NO CHANGE
- 3' TALL WALL – ADD .5' TO GEOGRID LENGTHS
- 4' TALL WALL – ADD .5' TO GEOGRID LENGTHS

**VERSA-LOK**  
Mosaic Wall System

Kirchner Block and Brick  
12901 St. Charles Rock Rd  
Bridgeton, MO 63044  
314/291-3200  
314/291-0265 fax

**TIERED WALL**

Sheet 10 of 10

Date: May 2008